

---

## HI TECH SMART HELMET SYSTEM

---

**Sanjeev Uppal**

Assistant Professor

Department of Electrical and Electronics Engineering  
SRM University, Delhi NCR

---

**ABSTRACT:** *An accident is a specific, unexpected, unusual and unintended external action which occurs in a particular time and place with no apparent and deliberate cause but with marked effects. Carelessness and neglect of safety measures on part of the driver are the major factors for accidents. Vehicle operators tend to violate the basic instructions given by the traffic authorities. The rising number of accidents involving motorcycles is an alarming issue. A statistical analysis of the same reflected the fact that a significant number of deaths could have been avoided, had there been a helmet. Nowadays most of the countries are forcing the motor riders to wear the helmet and not to use the vehicles when the person is in drunken condition. But still the rules are being violated by the users. In order to overcome this we have introduced an intelligent system, Smart Helmet. Most people tend to neglect the importance of the helmet and discard it. A statistical analysis of the same reflected the fact that a significant number of deaths could have been avoided, had there been a helmet. Most people tend to neglect the importance of the helmet and discard it. The Smart Helmet automatically detects whether the person is wearing the helmet and has non- alcoholic breath while driving. It also checks for rider drowsiness. Here we have a transmitter at the helmet and the receiver at the bike. There is a switch used to sure the wearing of helmet on the head. The ON condition of the switch ensures the placing of the helmet in proper manner. An alcohol sensor is placed near to the mouth of the driver in the helmet to detect the presence of alcohol. The data to be transferred is coded with RF encoder and transmitted through radio frequency transmitter. The receiver at the bike receives the data and decodes it through RF decoder. The bike has an integrated speed monitoring system which generates an alarm in case of over-speeding. The engine should not turn ON if any of the two conditions is violated. MCU controls the function of relay and thus the ignition, it controls the engine through a relay and a relay interfacing circuit.*

---

### I. INTRODUCTION

“To help ensure the safety and health of every human motorcyclist by designing a product that addresses their major concerns.” Our mission statement was finalized after several iterations of planning, development strategy, and performing market research.

A traffic accident is defined as any vehicle accident occurring on a public highway (i.e. originating on, terminating on, or involving a vehicle partially on the highway). These accidents therefore include collisions between vehicles and animals, vehicles and pedestrians, or vehicles and fixed obstacles. In higher-income countries, road traffic accidents are already among the top ten leading causes of disease burden as measured in DALYs (disability-adjusted life years). In less developed countries, road traffic accidents were the most significant cause of injuries, ranking eleventh among the most important causes of lost years of healthy life. In Indian road system, widening of the road is not an alternative solution to avoid traffic in such a cities. The problems with rider not wearing a helmet and drunken driving have to be solved. Application of electronics in the automobile field is very much popular now. Because of the low prices and various varieties available in the market people prefer motorbikes to buy over 4 wheelers. Hence Road Safety becomes a major issue of concern. Therefore it becomes necessary to implement such a technique which is not easy to bypass the basic rule of wearing helmet and to avoid drunken driving. Here we have designed a system which checks the two

conditions before turned ON the engine of the bike. Our system includes an alcohol sensor and a helmet sensing sensor. The IR Sensor is used to detect whether the biker is wearing helmet. Alcohol sensor is used to detect the biker is drunk, the output is fed to the MCU. There is also a blink sensor to detect any drowsiness of the rider. The blink sensor is basically an IR sensor coded accordingly. All of these sensors are fitted in the helmet. If any of the two conditions are violated the engine will not turned ON. In case of blink detected, it alarms the rider of the same. Alcohol sensor is used here for detecting the alcohol concentration present in the driver's breath. Sensor provides an analog resistive output based on the alcohol concentration. MCU is the microcontroller unit, which controls all the functions of other blocks in this system. MCU takes or read data from the sensors and controls all the functions of the whole system by manipulating these data. MCU receives data from these sensors and it gives a digital data corresponding to the output of sensors to the encoder only if the two conditions are satisfied. The bike has an integrated speed sensor which monitors the speed constantly and generates an alarm in case of any undue over-speeding, informing the driver about the same.

## II. BLOCK DIAGRAM

Vehicle accidents due to the use of alcohol have increased nowadays and the wearing of the helmet reduces the severity of the accidents. Our first iteration of the project consisted of a helmet with a built in smart mechanism that can communicate with the vehicle. Our goals for this project were to ensure rider safety through the means of introducing several features by means of the smart helmet.

The project can be broadly classified into two subparts, the Smart Helmet and the Processor circuit (which will be integrated to the bike).

The Smart Helmet section (Transmitting Section) consists of an alcohol sensor, helmet sensing sensor, Blink sensor, MCU, encoder and an RF transmitter. The sensors are fitted in the helmet. MCU reads data from the sensors, finds if the driver has non-alcoholic breath and helmet detection is in closed position and gives corresponding digital output to an encoder only if the two conditions are satisfied. It encodes one of the active inputs to a coded binary output. RF transmitter transmits this coded binary output from the encoder. Here we use the popular ASK modulation technique. In this RF system, the digital data is represented as variations in the amplitude of carrier wave. This kind of modulation is known as Amplitude Shift Keying (ASK).

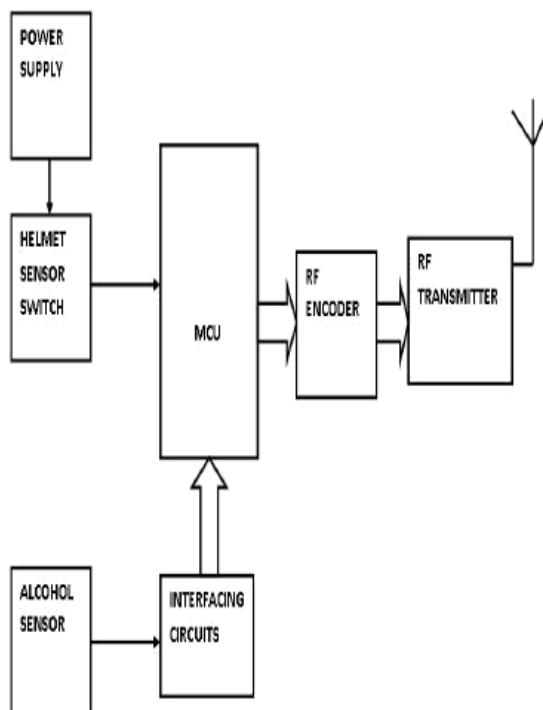

The receiver section is placed on the bike. It consists of an RF receiver, RF decoder, MCU, audio and visual indications. RF receiver receives the coded binary data transmitted by the RF transmitter and given to the RF decoder. RF decoder decodes the input and gives four bit digital data to the MCU only if the address bit of encoder and decoder matches. MCU operate the engine of the vehicle when it receives digital data from the transmitter section, it operates the engine through a relay circuit but it cannot operate the relay directly, so a relay interface is also used here.

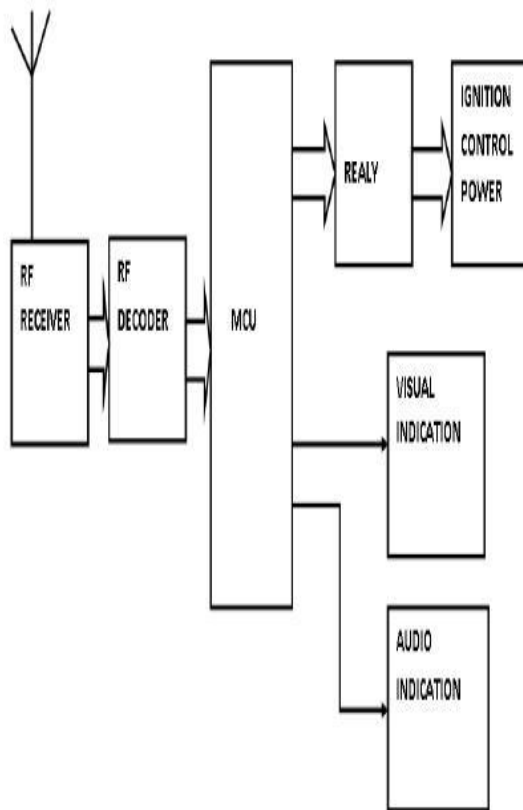

### III. WORKING PRINCIPLE

The helmet is integrated with an IR sensor just above the buckle. The transmitter and receiver are so attached that it detects the head of the rider (as an obstacle), and generates an output signal. The output of the IR sensor is fed into the Radio Frequency transmitter, which transmits it to the processor (integrated to the bike). The bike can only start (motor actuated) after the processor receives presence of helmet through the above mentioned steps. There is also an integrated alcohol sensor to the helmet such that it detects rider conditions. Any detection of alcohol is transmitted to the processor and it trips the relay to prevent starting of bike. The project also involves the constant monitoring of the bike speed, through Speed sensors ( IR sensor is used ). The helmet is equipped with blink detection facility (IR sensor). In case the rider is drowsy and takes longer time to blink or is drowsy, the sensor detects the same and intimates the processor about it. In any circumstance of over speeding, the processor intimates the rider of the over speeding conditions, so that the speed is brought down to safe limits. The transmission from helmet to processor is done wirelessly by the use of Radio Frequency module. Any restricted condition trips the relay to the actuator circuit and prevents starting of the bike, or intimates the rider about the same.

### IR SENSOR for helmet detection & blink sensor



#### IV. ANALYSIS

In this hardware setup includes the transmitter and receiver sections, the transmitter sections have alcohol sensing element, helmet detection unit, blink sensor, microcontroller unit, encoder and transmitter. The receiver section have decoder and receiver, microcontroller unit, ignition control, electrical device, audio and visual indication, power supply etc.

Alcohol sensing element: The alcohol sensing element used here is MQ-3 kind sensor, the facility offer to the alcohol sensing element is controlled through a NPN power electronic transistor TIP122 by the microcontroller unit. The bottom terminal of the voltage divider is connected to MCU through 1K resistance, from RC0 . The output of alcohol sensing element is connected to a voltage divider using 100K and 470 K variable. The output of the resistor is fed to op-amp's non-inverting voltage divider supported LM358. Output of non-inverting electronic equipment is fed to RA0/AN0 of the microcontroller. The presence of alcohol is detected by the microcontroller through this pin. During this system MQ3 is employed as LPG sensing element. This LPG/ alcohol sensing element is appropriate for detection terribly tiny presents of LPG in its surroundings. It's a high sensitivity and fast response. Sensing element provides analog resistive output depends on alcohol concentration. The drive circuit wants a resistance solely. a straight forward interface may well be a 0- 3.3V ADC. Resistance worth of MQ-3 is distinction varied to numerous sorts and various concentration gases. Once this element is used, sensitivity adjustment is extremely necessary

Microcontroller unit: AT89C51 is employed as the MCU. MCU gets power only when the helmet is worn. Then it additionally checks the output of alcohol sensing element as to whether or not alcohol is present or not. Then MCU communicates to the RF transmitter through the RF encoder circuit. Here the favored microcontroller AT89C5. The AT89C51 is a low-power, high-performance CMOS 8-bit microcomputer with 4 Kbytes of Flash Programmable and Erasable Read Only Memory (PEROM). The device is manufactured using Atmel's high density non-volatile memory technology and is compatible with the industry standard MCS-XXXXXXXXXX pin out. The on-chip Flash allows the program memory to be reprogrammed in-system or by a conventional non-volatile memory programmer. By combining a versatile 8-bit CPU with Flash on a monolithic chip, the Atmel AT89C51 is a powerful microcomputer which provides a highly flexible and cost effective solution to many embedded control applications. The AT89C51 provides the following standard features: 4 Kbytes of Flash, 128 bytes of RAM, 32 I/O lines, two 16-bit timer/counters, a five vector two-level interrupt architecture, a full duplex serial port, on-chip oscillator and clock circuitry. In addition, the AT89C51 is designed with static logic for operation down to zero frequency and supports two software selectable power saving modes. The Idle Mode stops the CPU while allowing the RAM, timer/counters, serial port and interrupt system to continue functioning. The Power down Mode saves the RAM contents but freezes the oscillator disabling all other chip functions until the next hardware reset.

Electrical relay: A relay is under controller that opens and closes underneath the control of another electrical circuit. In the original form, the switch is operated by an electromagnet to open or shut one or many sets of contacts. Because a relay is able to control an output circuit of upper power than the input circuit, it is thought of to be, in a broad sense, a form of an electrical amplifier. A simple electromagnetic relay is an adaptation of an electromagnet. It consists of a coil of wire surrounding a soft iron core, an iron yoke, which provides a low reluctance path for magnetic flux, a movable iron coil, and a set, or sets, of contacts. The coil is hinged to the yoke and automatically linked to a moving contact or contacts. It's control in place by a spring so that when the relay is de-energized there is an air gap in the magnetic circuit. In this condition, one of the 2 sets of contacts in the relay pictured is closed, and the other set is open. different relays may have a lot of or fewer sets of contacts depending on their operate when an electrical current is passed through the coil, the resulting magnetic field attracts the armature and the consequent movement of the movable contact or contacts either makes or breaks a connection with a fixed contact. If the set of contacts was closed when the relay was de-energized, then the movement opens the contacts and breaks the connection, and vice versa if the contacts were open, when the current to the coil is reduced to zero, the armature is returned by a force, approximately as strong as the magnetic force, to its relaxed position. Usually this force is provided by a spring, but gravity is also used commonly in industrial motor starters. Most relays are manufactured to operate quickly. In a low voltage application, this is to reduce noise.

## V. RESULT

Nowadays, most cases of accidents area unit by motor bikes. The severities of those accidents are increased because of the absence of helmet or by the usage of alcoholic drinks. In our project we have developed an electronic smart helmet system that efficiently checks the wearing of helmet and drunken driving. We have introduced advanced sensors techniques and radio frequency wireless communications are included in this project to make it a good one. Our system efficiently checks the wearing of helmet and drunken driving. By implementing this system a safe 2 wheeler journey is possible which would decrease the head injuries throughout accidents caused from the absence of helmet and additionally reduce the accident rate due to drunken driving.

## VI. FUTURE SCOPE

The project can be integrated with vibration sensors. These can sense any accident and when coupled to a gprs and gsm module, can send the coordinates of the accident site to the nearest police station, ambulance service, and near relatives.

There can be an integrated module to notify the No entry and No parking areas. Government should enforce laws to install such system in each 2 wheeler. By implementing such mechanism in 2 wheelers, the deaths attributable to due to driving and alternative road fatalities are often brought to zero p.c. And also indicates No parking area which would reduce the crowd of the vehicle in those areas. No entry area is mainly allocated during the development or repairing of the road, if the rider enters in such area this system would immediately intimate as No entry area and vehicle can stop automatically.

The Smart Helmet can be integrated to Google Maps or HERE Drive, to navigate the rider to his destination, avoid traffic snarls and hence offer a hassle free drive.

## REFERENCE

1. International Journal of Science and Research (IJSR) ISSN (Online): 2319-7064 Volume 3 Issue 3, March 2014
2. International Journal Of Computer Science And Applications Vol. 6, No.2, Apr 2013 ISSN: 0974-1011 (Open Access)
3. Article from The Hindu [online] 2011 Feb. 10 Available from: URL:<http://www.hindu.com/2011/02/10/stories/2011021063740500.htm>
4. International Journal of Scientific & Engineering Research Volume 2, Issue 12, December-2011 1 ISSN 2229-5518
5. Bishop, R (2002). The road ahead for intelligent vehicle sytem: what's in store for riders?
6. 8th Annual Minnesota Motorcycle safety conference
7. Sayeed and A. Perrig, "Secure Wireless Communications: Secret Keys through Multipath," Proc. IEEEInt'l Conf. Acoustics, SpeechSignal Processing, pp. 3013-3016, Apr.2008
8. William R. Reagen, (1979) —Auto theft detection systeml US4177466 (US Patent)
9. Computer", May 2011
10. Road accidents in India [online] 2007 June 25. Available from: URL: <http://www.easydriveforum.com/f44-share-yourroad-experience/road-accidents-in-india-834.html>
11. Articles base directory [online] 2011 Feb. 16 Available from: URL: <http://www.dwworld.de/dw/article/0,,5519345,00.html>
12. Article from The Hindu [online] 2011 Feb. 10
13. Available from: URL:<http://www.hindu.com/2011/02/10/stories/2011021063740500.htm>
14. Drunk Drivers Beware Of Saab Device,[<http://www.buzzle.com/articles/drunkdrivers-beware-saab-device.html>]
15. Nissan to drink drive—proof its vehicles, September 2006,[[http://www.nissanglobal.com/EN/NEWS/2007/\\_STORY/070723-01](http://www.nissanglobal.com/EN/NEWS/2007/_STORY/070723-01)]
16. Alcohol sensor and Automatic control system for bike, Volume 2, Issue ICRAET12, May 2012, ISSN Online: 2277-2677.
17. [www.wikipeia.org/wiki/](http://www.wikipeia.org/wiki/)
18. [www.electronicsforu.com](http://www.electronicsforu.com)